

RoHS GP HF

REV.	ECR/N NO.	DESCRIPTION	DRAWN	DATE
A	/	NEW	Li Song	2021/10/26

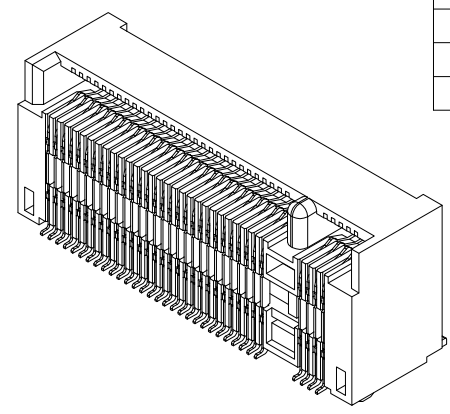

- Notes:
- Materials
 - Housing: LCP+30% GF,UL94 V-0 COLOR: BLACK;
 - Contact: COPPER ALLOY T=0.15mm, Gold Plating at mating area Matte Tin Plating or GF at solder tail,all over Nickel;
 - PEG: COPPER ALLOY T=0.20mm, Matte Tin And Nickel Plating over all.
 - RoHS 2.0 and HF compliant;
 - Ratings
 - Voltage Rating: 50V AC (Per pin);
 - Current Rating: 0.5A (Per pin);
 - Operating Temperature: -40°C ~ 80°C;
 - Electrical Requirement:
 - LLCR: 55mΩ Max,(Initial), 20mΩ Max. change allowed(Final);
 - Dielectric Withstanding Voltage: 300V AC (RMS) for 1 minute;
 - Insulation Resistance: 500MΩ Min. @ 500V DC;
 - Mechanical Requirement:
 - Mating Force: 20N Max.;
 - Unmating Force: 25N Max.;
 - Durability: 60 Cycles;
 - Vibration: No electrical discontinuity greater than 1u sec shall occur;
 - Mechanical Shock: 285G half sine / 6 axis
No electrical discontinuity greater than 1u sec shall occur;
 - Resistance to heat: the temperature shall be 260±5°C 10±1 seconds.

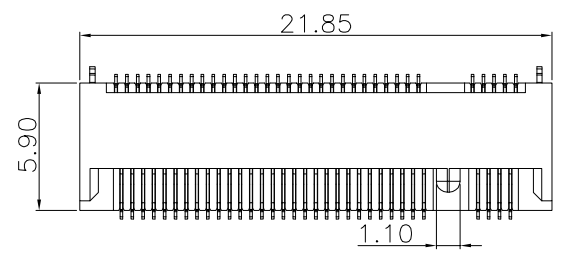
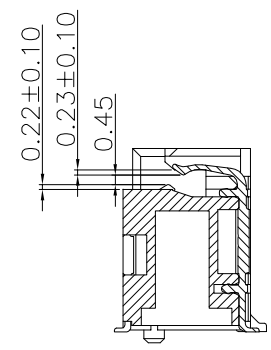
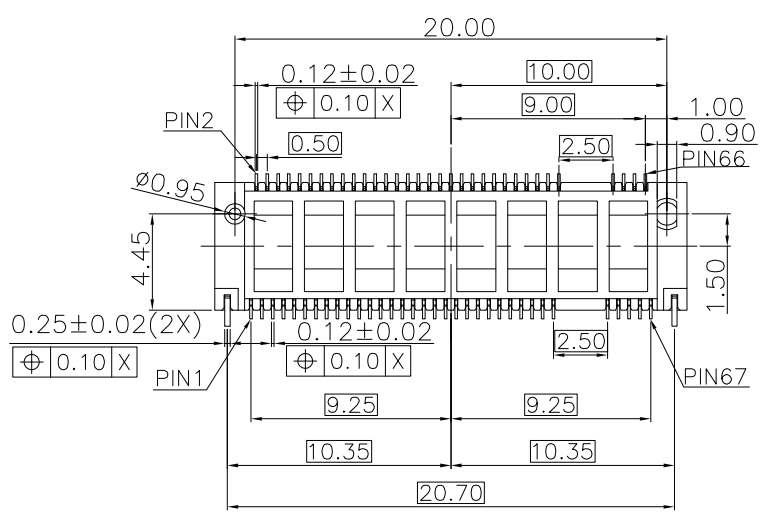
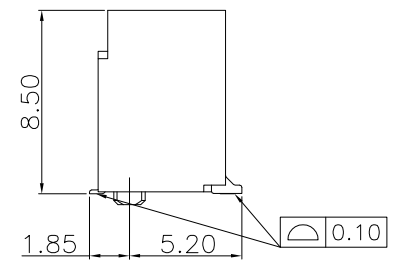
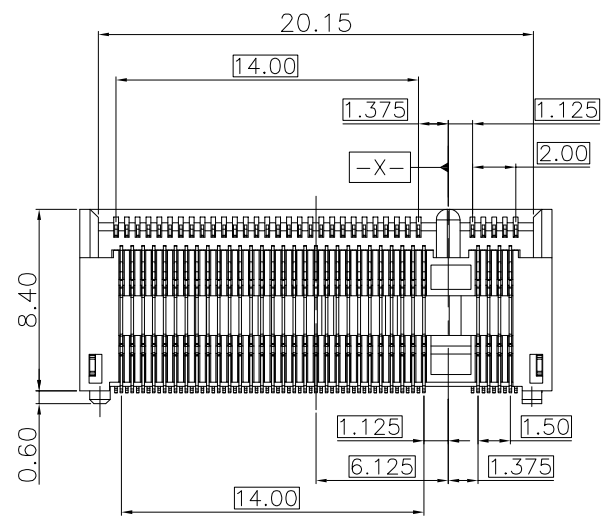

TOLERANCE	MODEL NAME: M. 2, KEY, M, H=8.5, BLACK	DRAWN: Li Song
X.X ±0.35	MODEL NO: SEE TABLE	CHECKED: Youhua Cai
X.XX ±0.25	UNIT: mm	APPROVED: Youhua Cai
X.XXX ±0.10	SCALE: 1:1	DATE: 2021/10/26
ANGLE ±1.0°	REVISION: A	DWG NO: C-WLM2-67P01
	SHEET: 1/2	FILE: C

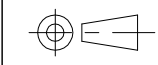

WILCO 深圳市兴万联电子有限公司
SHENZHEN XING WAN LIAN ELECTRONICS CO., LTD.

REV.	ECR/N NO.	DESCRIPTION	DRAWN	DATE
A	/	NEW	Li Song	2021/10/26

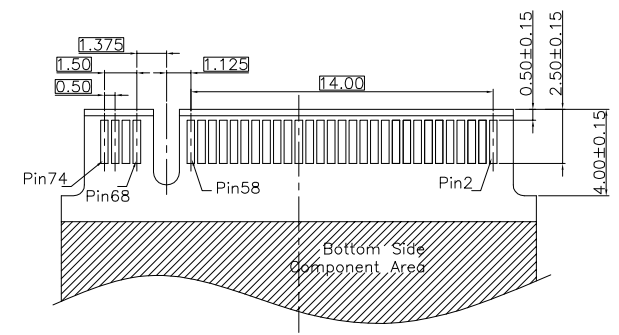
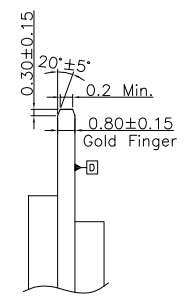
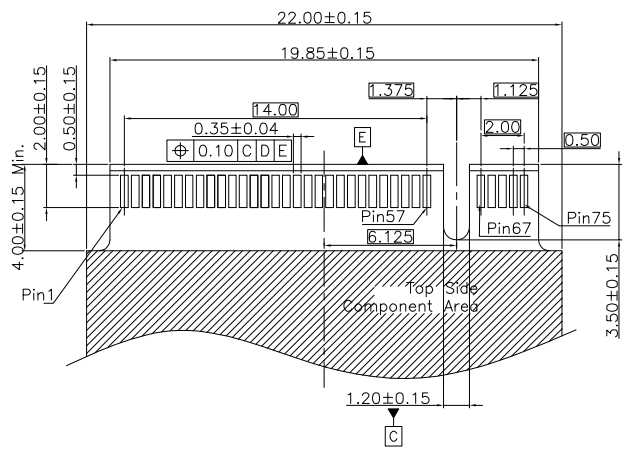

Recommended Mould Finger Layout
Default Tolerance ±0.05

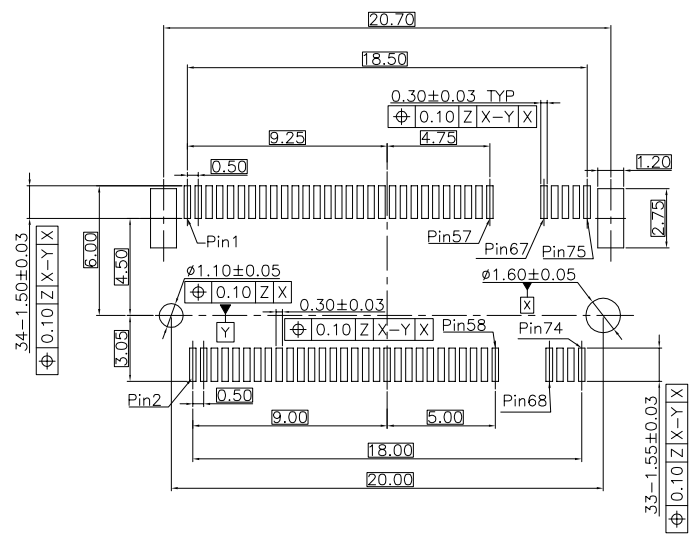

TABLE

NO.	PART NO	SPECIFICATION
1	WLM2-005A	HOUSING_LCP BLACK UL94-V0, CONTACT_C5210 G/F Ni50u, PEG_C5191 NICKEL PLATING
2	WLM2-006A	HOUSING_LCP BLACK UL94-V0, CONTACT_C5210 15u Ni50u, PEG_C5191 NICKEL PLATING

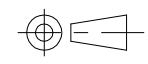
TOLERANCE X.X ±0.35 X.XX ±0.25 X.XXX ±0.10 ANGLE ±1.0°	MODEL NAME: M. 2, KEY, M, H=8. 5, BLACK				DRAWN: Li Song
	MODEL NO: SEE TABLE				CHECKED: Youhua Cai
mm	UNIT:	SCALE:	REVISION:	SHEET	APPROVED: Youhua Cai
	1:1	A	2/2	DATE: 2021/10/26	
 WLCO 深圳市兴万联电子有限公司 SHENZHEN XING WAN LIAN ELECTRONICS CO., LTD.	DWG NO: C-WLM2-67P01				FILE: C